

use & care guide



Whirlpool

Estate SERIES

**ELECTRIC
RANGE**

**Self-Cleaning
Model RF360EXP**

Microwave Ovens, Trash Compactors, Room Air Conditioners, Dehumidifiers, Automatic Washers, Clothes Dryers, Freezers, Refrigerator



Contents

	Page		Page
BEFORE YOU USE YOUR RANGE	2	Optional Rotisserie	13
IMPORTANT SAFETY		CARING FOR YOUR RANGE	13
INSTRUCTIONS	3	Control Panel	13
PARTS AND FEATURES	4	Surface Units and	
USING YOUR RANGE	5	Reflector Bowls	13
Using the Surface Units	5	Lift-Up Cooktop	15
Optional Canning Kit	6	Lower Panel	16
Setting the Clock	6	Using the Self-Cleaning	
Using the Minute Timer	7	Cycle	17
Using the Oven Controls	7	Cleaning Chart	20
Baking	7	IF YOU NEED SERVICE OR	
Broiling	9	ASSISTANCE	22
Using the Automatic		WHIRLPOOL RANGE	
MEALTIMER® Control	11	WARRANTY	24
Oven Vent	12		

©1987 Whirlpool Corporation

Before you use your range

Read this Use & Care Guide and The Cooking Guide for important safety information.

You are personally responsible for:

- Reading and following all safety precautions in this Use & Care Guide and the Cooking Guide.
- Installing the range where it is protected from the elements, and on a floor strong enough to support its weight.
- Properly connecting the range to electrical supply and grounding. (See "Installation Instructions.")
- Making sure the range is not used by anyone unable to operate it properly.
- Properly maintaining the range.
- Using the range only for jobs expected of a home range.

See "Cooking Guide" for important safety and use information.

IMPORTANT SAFETY INSTRUCTIONS



WARNING – When using your range, follow basic precautions, including the following:

1. **DO NOT** allow children to use or play with any part of the range, or leave them unattended near it. They could be burned or injured.
2. **DO NOT** store things children might want above the range. Children could be burned or injured while climbing on it.
3. **DO NOT** allow anyone to touch hot surface units or heating elements. Dark colored units and elements can still be hot enough to burn severely.
4. **KEEP** children away from the range when it is on. The cooktop and oven walls, racks and door can get hot enough to cause burns.
5. **DO NOT** use the range to heat a room. Persons in the room could be burned or injured, or a fire could start.
6. **KEEP** pan handles turned in, but not over another surface unit to avoid burns, injury and to help prevent the utensil from being pushed off the surface units.
7. **DO NOT** use water on grease fires. The fire will spread. Cover fire with large lid or smother with baking soda or salt.
8. **DO NOT** wear loose or hanging garments when using the range. They could ignite if they touch a hot surface unit or heating element and you could be burned.
9. **DO NOT** heat unopened containers. They could explode. The hot contents could burn and container particles could cause injury.
10. When adding or removing food, **MAKE SURE** to open the oven door all the way to prevent burns.

• FOR YOUR SAFETY •

DO NOT STORE OR USE GASOLINE OR OTHER FLAMMABLE VAPORS AND LIQUIDS IN THE VICINITY OF THIS OR ANY OTHER APPLIANCE. THEY COULD IGNITE CAUSING EXPLOSION AND/OR FIRE.

– SAVE THESE INSTRUCTIONS –

Copy your Model and Serial Numbers here

If you need service, or call with a question, have this information ready:

1. **Complete** Model and Serial Numbers (from plate just behind the oven door).
2. Purchase date from sales slip. Copy this information in these spaces. Keep this book, your warranty and sales slip together in the Literature Pac.

Please complete and mail the Owners Registration Card furnished with this product.

Model Number

Serial Number

Purchase Date

Service Company Phone Number

Parts and features

Model RF360EXP

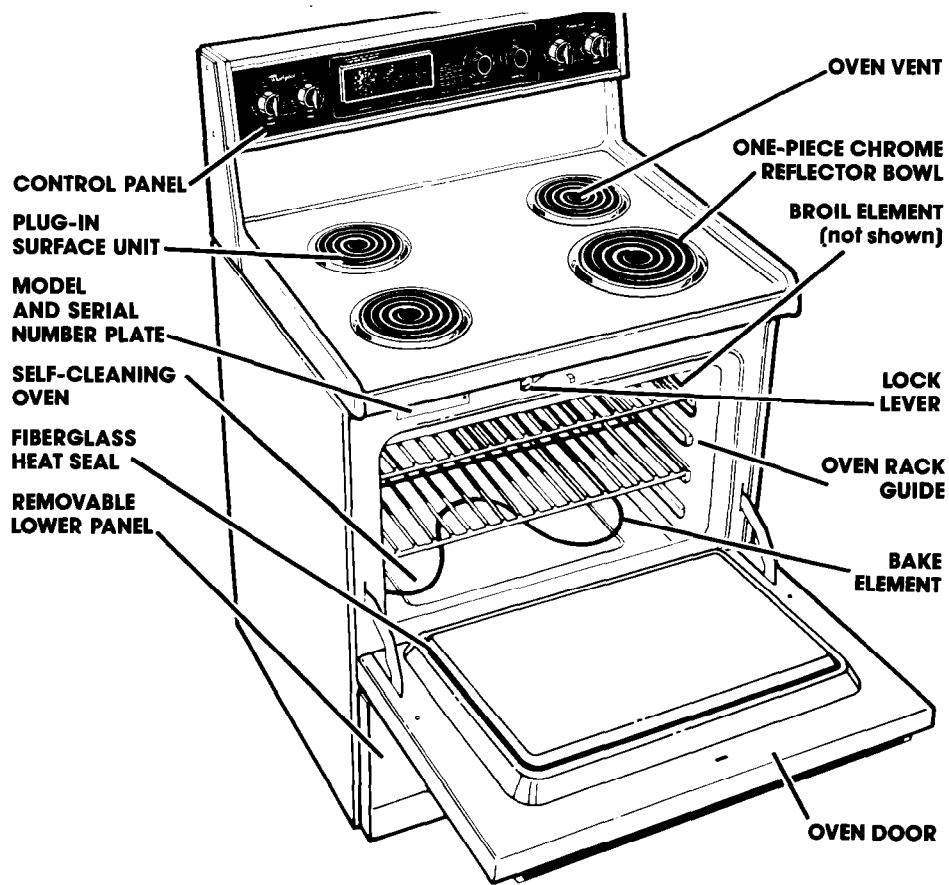
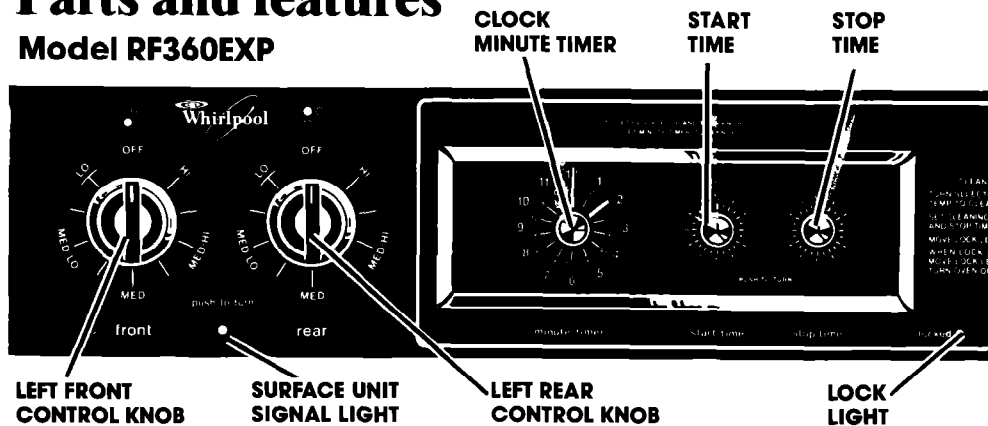

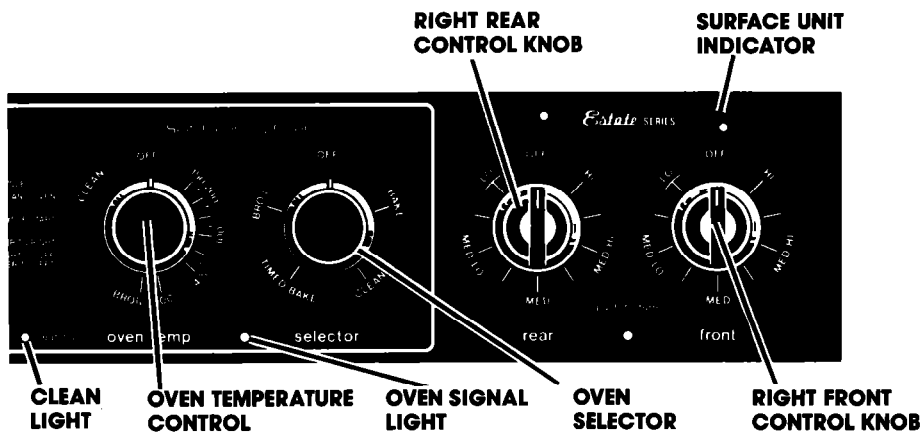

Using the surface units

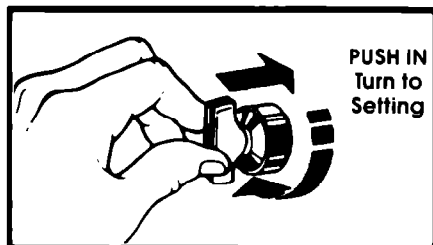

Control knobs must be pushed in before turning them to a setting. They can be set anywhere between HI and OFF.

Surface Unit Indicators

The solid dot in the surface unit indicator shows which surface unit is turned on by that knob.

Signal Light

One of the signal lights will glow when a surface unit is on.



WARNING: Be sure all lights are OFF when you are not cooking. Someone could be burned or a fire could start if a surface unit is accidentally left ON.

Until you get used to the settings, use the following as a guide. For best results, start cooking at the high settings; then turn the control knob down to continue cooking.

Use HI to start foods cooking; to bring liquids to a boil.

Use MED-HI to hold a rapid boil; to fry chicken or pancakes.

Use MED for gravy, puddings and icing; to cook large amounts of vegetables.

Use MED-LO to keep food cooking after starting it on a higher setting.

Use LO to keep food warm until ready to serve. Set the heat higher or lower within the LO band to keep food at the temperature you want.

CAUTION: The use of the HI setting for long periods of time can damage surface units and discolor chrome reflector bowls. Start cooking on HI and turn control down to continue cooking.

Use only flat-bottomed utensils for best cooking results and to prevent damage to the cooktop. Specialty items with rounded or ridged bottoms (woks, ridged bottom canners or tea kettles) are not recommended.



WARNING: The surface unit should never turn red during use. If it turns red, the bottom of the pan is not flat enough or is too small for the size of the surface unit. Damage to the surface unit, cooktop, wiring and/or surrounding area could result. If the pan is too small for the surface unit, you could be burned by the heat from the exposed section of the surface unit.

See the “Cooking Guide” for important utensil information.

Optional Canning Kit (Part No. 242905)

The large diameter of most water-bath or pressure canners combined with high heat settings for long periods of time can shorten the life of regular surface units and cause damage to the cooktop.

If you plan to use the cooktop for canning, we recommend the installation of a Canning Kit. Order the kit from your Whirlpool Dealer or Tech-Care[®] Service Company.

See the “Cooking Guide” for important canning information.

Setting the Clock

Push in and turn the Minute Timer Knob to set the Clock.

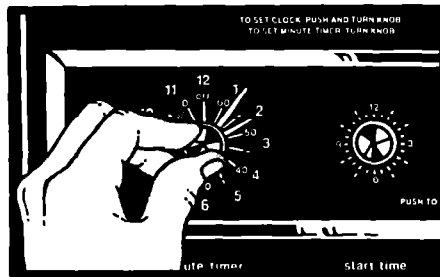

- 1. Push in Minute Timer Knob and turn clockwise** until clock shows the right time of day.

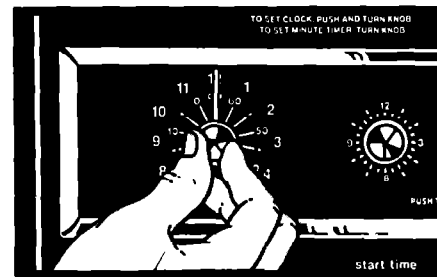

- 2. Let the Minute Timer Knob pop out.** Turn clockwise until Minute Timer hand points to OFF. **The clock setting will change if you push in the knob when turning.**

Using the Minute Timer

The Minute Timer does not start or stop the oven. It works like a kitchen timer. Set it in minutes up to an hour. You will hear a buzzer when the set time is up.

DO NOT PUSH IN THE KNOB when setting the Minute Timer.

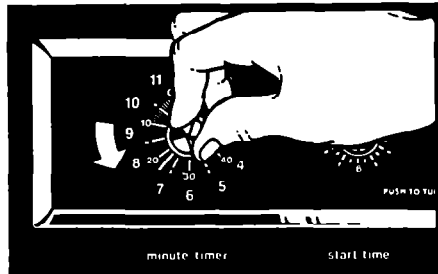

1. **Without pushing it in**, turn the Minute Timer Knob until the hand passes the setting you want.

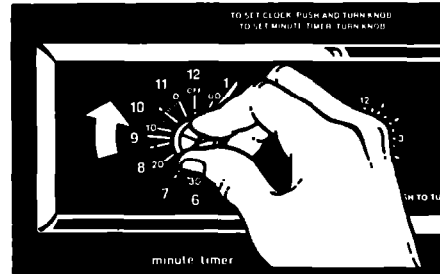

2. **Without pushing in**, turn the knob back to the setting you want.
When the time is up, a buzzer will sound. To stop the buzzer, turn the Minute Timer hand to OFF.

PUSHING IN AND TURNING THE MINUTE TIMER KNOB CHANGES THE CLOCK SETTING.

Using the Oven Controls

Baking

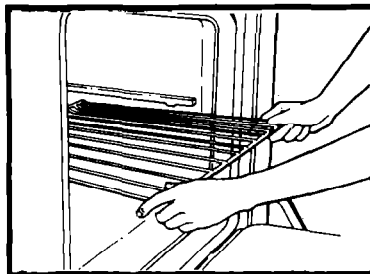

1. Position the rack(s) properly **before** turning on the oven. To **change rack position**, lift rack at front and pull out.

Rack(s) should be placed so the top of the food will be centered in the oven. Always leave at least 1½ to 2 inches (4-5 cm) between the sides of the pan and the oven walls and other pans. For more information, see the "Cooking Guide."

continued on next page

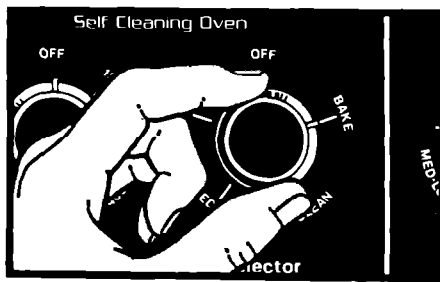

2. Set Oven Selector to BAKE.

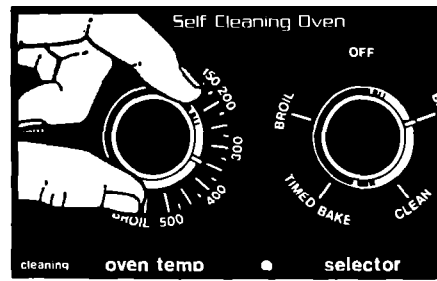

3. Set Oven Temperature Control to the baking temperature you want. The Oven Signal Light will come on. The oven is preheated when the Oven Signal Light first goes off.

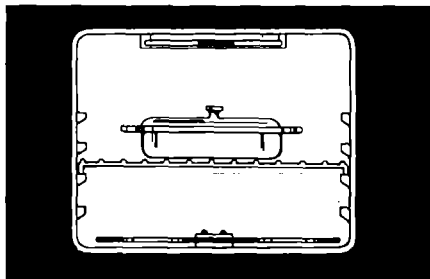

4. Put food in the oven. **Note: Oven racks, walls and door will be hot.**

During baking, the elements will turn on and off to keep the oven temperature at the setting. The Oven Signal Light will turn on and off with the elements.

The top element helps heat during baking, but does not turn red.

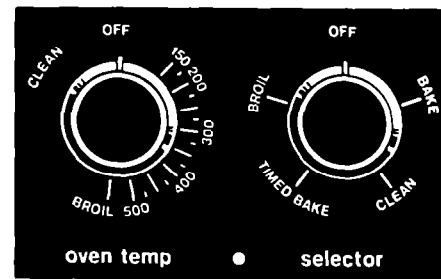

5. When baking is done, turn both the Oven Temperature Control and the Oven Selector to OFF.

Adjusting the Oven Temperature Control

Does your oven seem hotter or colder than your old oven? The temperature of your old oven may have shifted gradually without your noticing the change. Your new oven is properly adjusted to provide accurate temperatures. But when comparing to your old oven, the new design may give you different results.

If after using the oven for a period of time, you are not satisfied with the temperature settings, they can be adjusted by following these steps:

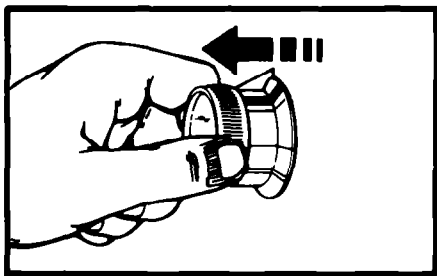

1. Pull the Oven Temperature Control straight off.

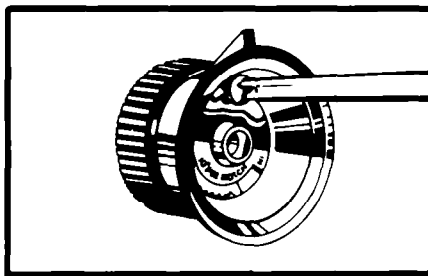

2. Loosen the locking screw inside the control knob. **Note the position of the notches.**

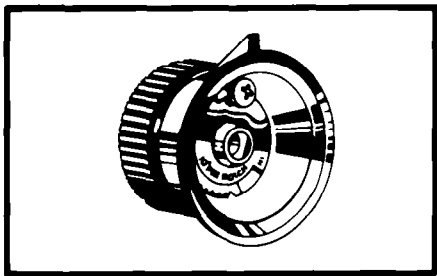

3. To lower the temperature, move black part of knob closer to LO. Each notch equals about 10°F (5°C).

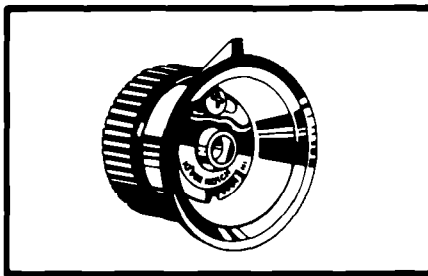

4. To raise the temperature, move black part of knob closer to HI. Each notch equals about 10°F (5°C).

Tighten the locking screw and replace the control knob.

Broiling

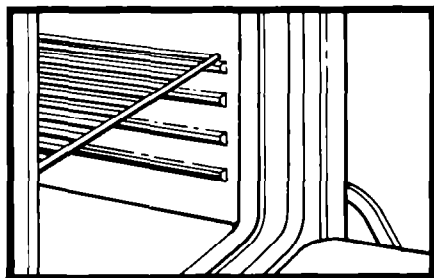

1. Position the rack before turning the oven on. See broil chart in the "Cooking Guide" or a reliable cookbook for recommended rack positions.

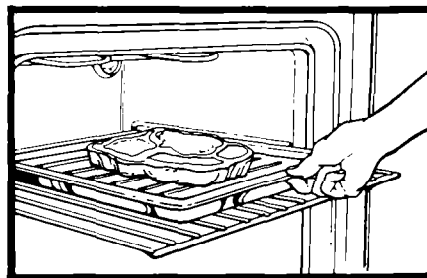

2. Put the broiler pan and food on the rack.

continued on next page

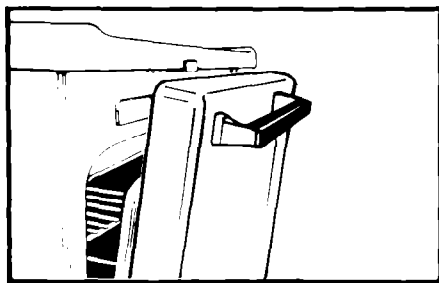

3. Close the door to the Broil Stop position, (open about 4 inches, 10.2 cm). The door will stay open by itself.



5. When broiling is done, turn **both** the Oven Selector and the Oven Temperature Control to OFF.



4. Set the Oven Selector and the Oven Temperature Control to BROIL.

Custom Broil

- If food is cooking too fast, turn the Oven Temperature Control **counterclockwise** until the Oven Signal Light goes off.
- If you want the food to broil slower from the start, set the Oven Temperature Control between 150° and 325°F (65.5° and 162.7°C). The lower the temperature, the slower the cooking.

The Oven Selector must be on BROIL for all broiling temperatures.

CAUTION: The door must be partly open whenever the oven is set to BROIL. Leaving the door open allows the oven to maintain proper temperatures.

Using the Automatic MEALTIMER* Clock

The automatic MEALTIMER* Clock is designed to turn the oven on and off at times you set, even when you are not around.

Automatic baking is ideal for foods which do not require a preheated oven such as meats and casseroles. **Do not use the automatic cycle for cakes, cookies, etc... undercooking will result.**

To start and stop baking automatically:

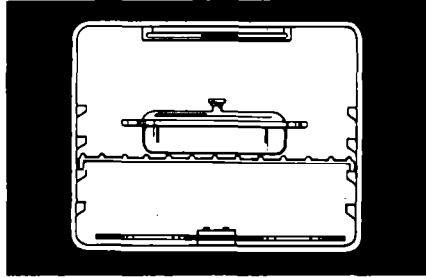

1. Position the oven rack(s) properly, and place the food in the oven.

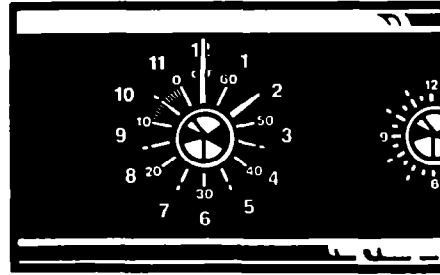

2. Make sure the clock is set to the correct time of day.

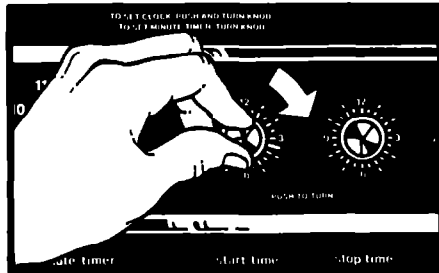

3. Push in and turn the Start Time Knob **clockwise** to the time you want baking to start.

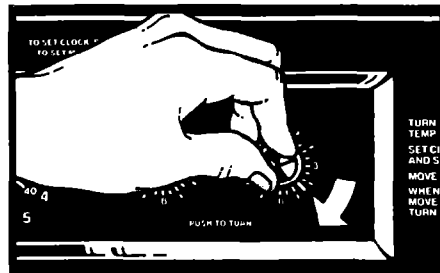

4. Push in and turn the Stop Time Knob **clockwise** to the time you want the oven to shut off.

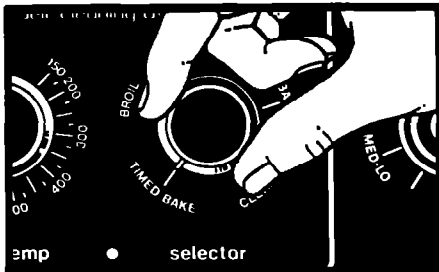

5. Set the Oven Selector on TIMED BAKE.



6. Set the Oven Temperature Control on the baking temperature you want. The oven will now start and stop automatically. **After baking is done or to stop the oven before preset time**, turn both the Oven Selector and the Oven Temperature Control to OFF.

To start baking now and stop automatically:

1. Position the oven rack(s) properly, and place the food in the oven.
2. Make sure the clock is set to the right time of day.
3. Push in and turn the Stop Time Knob **clockwise** to the time you want the oven to shut off.
4. Set the Oven Selector to TIMED BAKE.
5. Set the Oven Temperature Control to the baking temperature you want.
6. **After baking is done or to stop the oven before the preset time,** turn both the Oven Selector and the Oven Temperature Control to OFF.



WARNING: To avoid sickness and food waste:

- Use foods that will not go bad or spoil while waiting for cooking to start.
- Avoid using dishes with milk or eggs, cream soups, cooked meats or fish, or any item with baking powder or yeast.
- Any food that has to wait for cooking to start should be very cold or frozen before it is put in the oven. **MOST UNFROZEN FOODS SHOULD NEVER STAND MORE THAN TWO HOURS BEFORE COOKING STARTS.**

The Oven Vent

The oven vent is located under the right rear surface unit. When the oven is on, hot air and moisture escape from the oven through this vent. Poor baking can result if this vent is blocked. When using the oven, **do not** use oversized pans or other items that might block the oven vent.

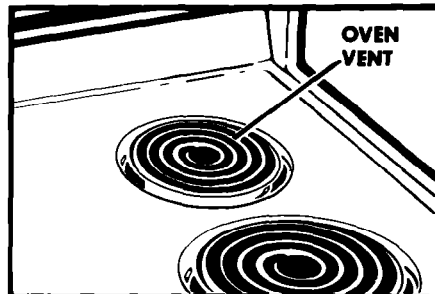

WARNING: When the oven is ON, pans and pan handles left over the right rear surface unit can become hot enough to burn the user and to melt plastics. Use pot holders to move pans. Never store plastic, paper or other items that could melt or burn on any of the surface units.

Optional Rotisserie

If you would like a rotisserie for your lower oven, you can order kit RCK-79 (Part No. 261881) from your Whirlpool Dealer. The kit includes easy installation instructions.

Caring for your range

Control Panel

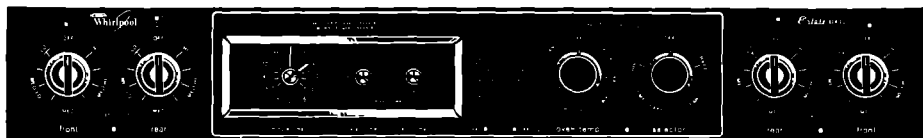

1. Pull knobs straight off.
2. Use warm soapy water and a soft cloth, or spray glass cleaner, to wipe the control panel. Rinse and wipe dry.
3. Wash control knobs in warm soapy water. Rinse well and dry.
4. Push control knobs straight back on. Make sure they point to OFF.

Surface Units and Reflector Bowls

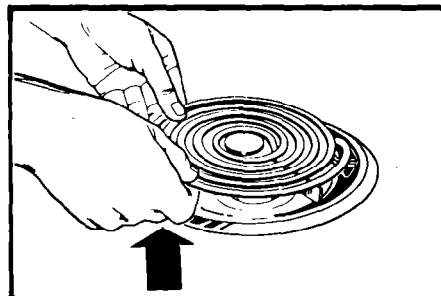
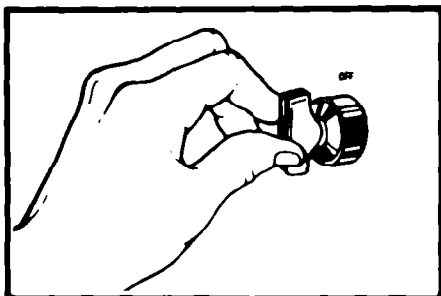

1.  **WARNING:** To avoid burns and possible electric shock, be sure surface units are OFF and COOL.

2. Lift the edge of the unit, opposite the receptacle, just enough to clear the reflector bowl.

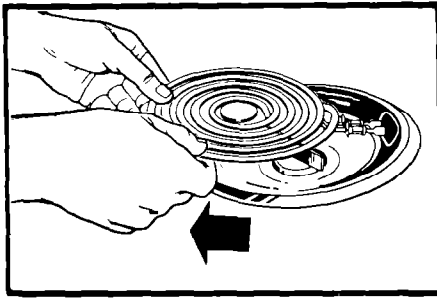

3. Pull the surface unit straight away from the receptacle.

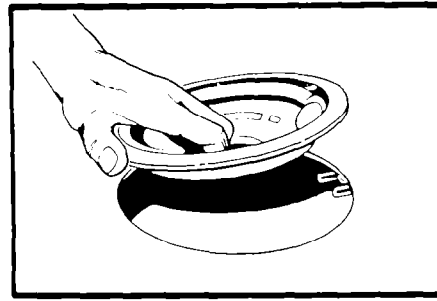

4. Lift out the reflector bowl. See Cleaning Chart on page 21 for cleaning instructions.

Replacing

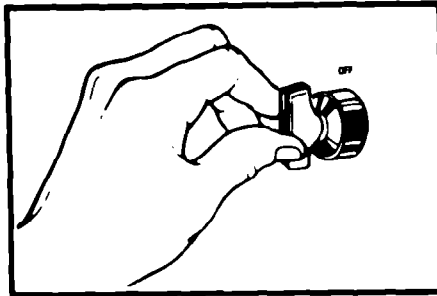

1.

 **WARNING: To avoid burns and possible electric shock, be sure surface units are OFF.**

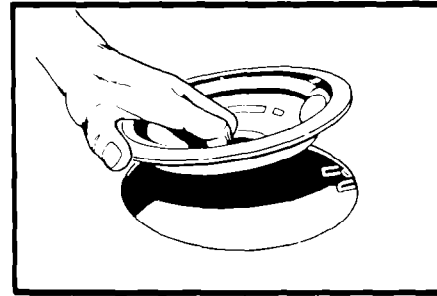

2. Line up opening in the reflector bowl with the surface unit receptacle.

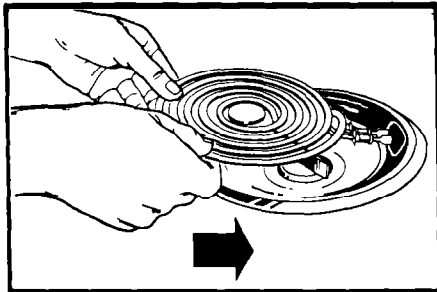

3. Hold the surface unit as level as possible with the terminal just started into the receptacle.

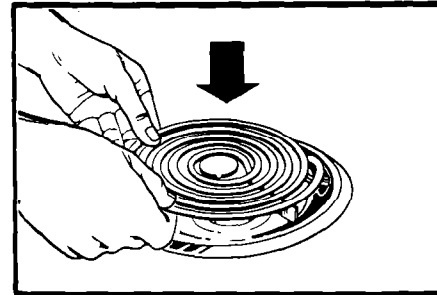

4. Push the surface unit terminal into the receptacle. When the terminal is pushed into the receptacle as far as it will go, the surface unit will fit into the reflector bowl.

CAUTION: Reflector bowls reflect heat back to the utensils on the surface units. They also help catch spills. When they are kept clean, they reflect heat better and look new longer.

If a reflector bowl gets discolored, some of the utensils may not be flat enough, or some may be too large for the surface unit. In either case, some of the heat that's meant to go into or around a utensil goes down and heats the reflector bowl. This extra heat can discolor it. See "Cooking Guide" for further information.



WARNING – DO NOT LINE THE REFLECTOR BOWLS WITH FOIL.
Shock or fire hazard could result.

Lift-Up Cooktop

1. Lift front of cooktop at center and swing-up the support rod.
2. Carefully lower the cooktop onto the support rod.



WARNING: Be sure the rod fits in the notch in the cooktop and is held securely. The cooktop could accidentally fall and injure you.

3. Wipe with warm soapy water. Use soapy steel-wool pad on stubborn spots.

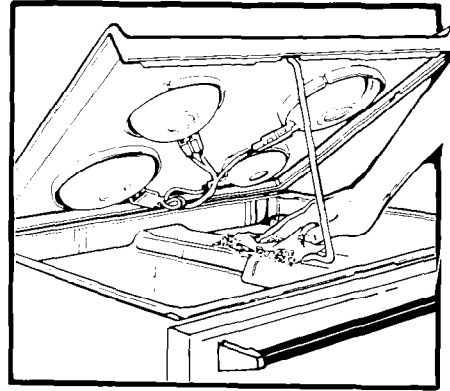

CAUTION: Do not drop the cooktop. Damage can result to the porcelain and the cooktop frame.

The Lower Panel

The lower panel can be removed to help make it easier to clean under the range.

To remove the lower panel:

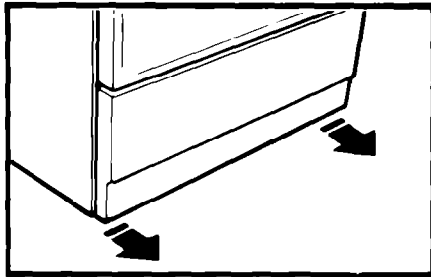

1. Pull out bottom of panel.

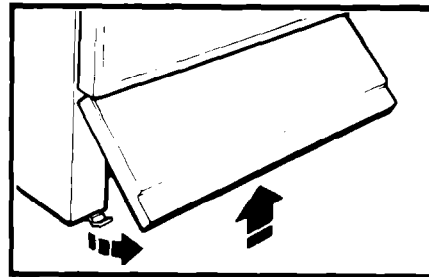

2. Slightly swing out and lift panel to remove from top clips.

To replace lower panel:

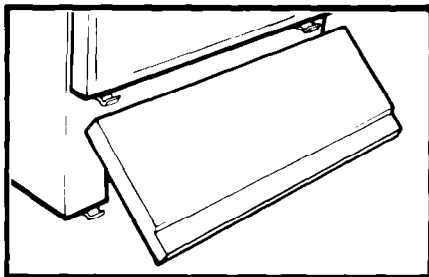

1. Place notches in top of panel over the top clips.

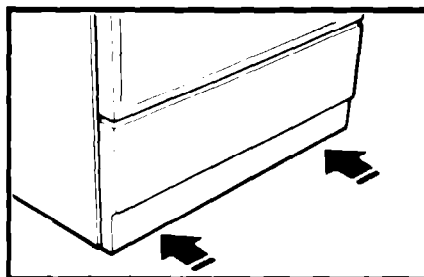

2. Swing down and push bottom of panel to secure bottom clips.

Using the Self-Cleaning Cycle

The self-cleaning cycle uses **very high heat** to burn away soil. Before you start, make sure you understand exactly how to use the cycle safely.

Before You Start

1. Clean the shaded areas by hand. They do not get hot enough during the Self-Clean cycle for soil to burn away. Use hot water and detergent or a soapy steel-wool pad on...
 - the frame around the oven.
 - the inside of the door, especially the part outside the oven seal.

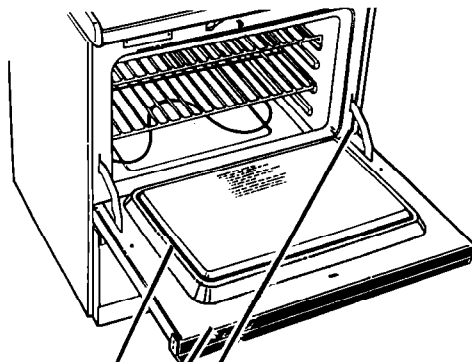

DO NOT
Clean Seal
Clean Door
Clean Frame

DO NOT clean the fiberglass seal. DO NOT move it or bend it. Poor cleaning and poor baking will result.

2. Remove the broiler pan and any pots or pans you may have stored in the oven. They can't stand the high heat.
3. Wipe out any loose soil or grease. This will help reduce smoke during the cleaning cycle.
4. If your oven has a rotisserie, make sure the motor socket cover is closed.
5. Put oven racks on the second and fourth guides (counting from the bottom). During the Self-Cleaning Cycle they will darken and become harder to slide. See tips on page 19. If you want the oven racks to remain shiny, clean them by hand.

Chrome reflector bowls must not be cleaned in the oven. They will discolor.

Turn on the vent hood or other kitchen vent during the cleaning cycle. This will help remove smoke, odor and heat that are normal during the cycle.

SPECIAL CAUTIONS:

DO NOT use commercial oven cleaners in your oven. Damage to the porcelain finish may occur.

DO NOT force the Lock Lever, you could bend or break it. The lever is designed to stay locked until the oven is cool enough to safely open. Wait until it moves freely.

DO NOT use foil or other liners in the oven. During the cleaning cycle foil can burn or melt and damage the oven surface.



WARNING: DO NOT block the vent during the cleaning cycle. Air must move freely for best cleaning results.

DO NOT leave a utensil over the right rear surface unit during the cleaning cycle. It will become hot enough to burn you and the utensil could be damaged.

DO NOT TOUCH THE COOKTOP OR OVEN DURING THE CLEANING CYCLE. THEY COULD BURN YOU

Setting the Controls

Be sure the kitchen is ventilated during the Self-Cleaning cycle. This will help normal smoke and heat odors to disappear from the room as quickly as possible.

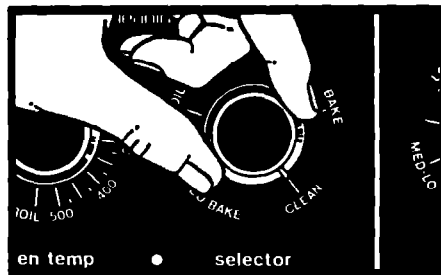

1. Set the Oven Selector and the Oven Temperature Control on CLEAN.

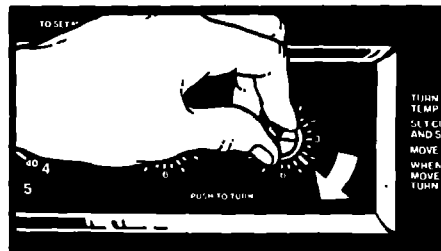

3. Push in and turn the Stop Time Knob **clockwise** 2 or 3 hours.
 - Use 2 hours for light soil.
 - Use 3 hours or more for moderate to heavy soil.



5. The Lock Light comes on when the oven temperature exceeds normal baking temperatures. The Lock Lever must not be moved and the door can't be opened when this light is on.

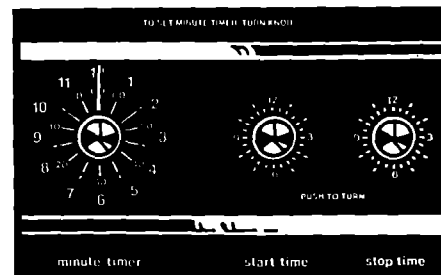

2. Make sure the Clock, Start and Stop Times all have the right time of day.

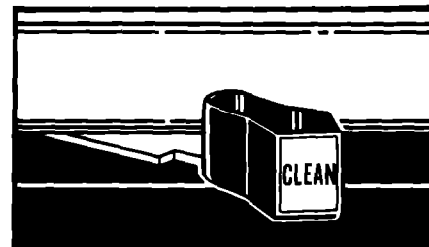

4. Move the Lock Lever to the Clean Position. The Clean Light will come on only when the lever is all the way to the right.

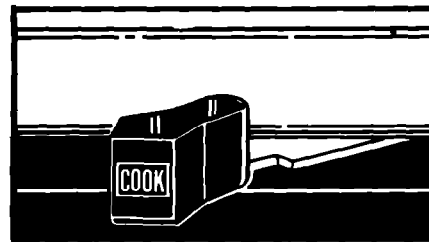

6. After the Clean Cycle is completed, the Lock Light goes off. Move the Lock Lever back to the Cook Position. **Do not force it.** Wait until it moves easily. This turns off the Clean Light. Turn the Oven Selector and the Oven Temperature Control to OFF.

After the oven is cool, wipe off any residue or ash with a damp cloth. If needed, touch up spots with a soapy steel wool pad.

Special Tips

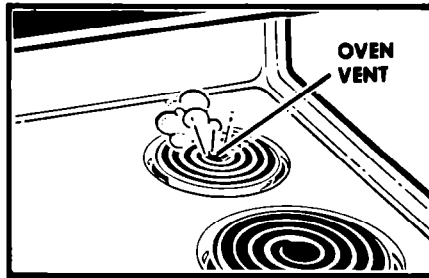

Keep the kitchen well ventilated during the cleaning cycle to help get rid of normal heat, odors and smoke.

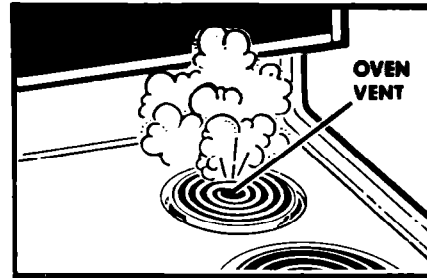

Clean the oven before it gets heavily soiled. Cleaning a very soiled oven takes longer and results in more smoke than usual.

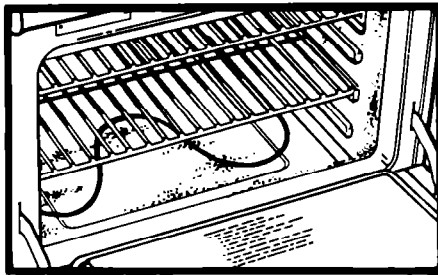

If the cleaning cycle doesn't get the oven as clean as you expected, the cycle may not have been set long enough or you may not have prepared the oven properly. Set the cleaning time longer the next time and hand clean areas noted on page 17.

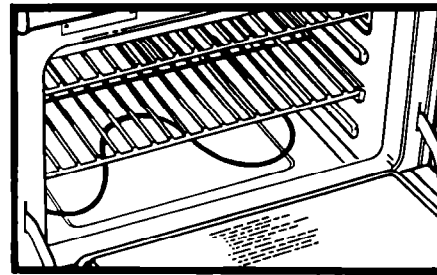

Oven racks lose their shine, discolor and become harder to slide on their guides when they are left in the oven during the cleaning cycle. To make them slide easier, polish the edges of the racks with a soapy steel-wool pad, rinse well and wipe on a thin coat of salad oil.

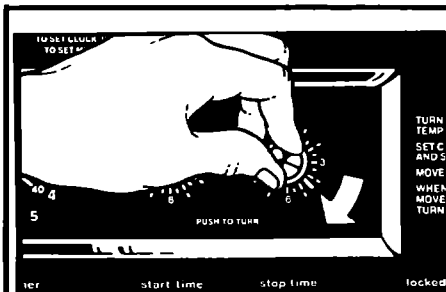

To stop the cleaning cycle at any time:

1. Push in and turn the Stop Time Knob **clockwise** until it points to the right time of day.



2. Turn the Oven Selector and Oven Temperature Control to OFF. When the Lock Light turns off, move the Lock Lever back to the Cook Position. **DO NOT FORCE IT.** Wait until it moves easily.



WARNING: DO NOT TOUCH THE RANGE DURING THE CLEANING CYCLE. IT CAN BURN YOU.

How It Works

During the self-cleaning cycle, the oven gets much hotter than it does for baking or broiling...approximately 875°F (468°C). This heat breaks up grease and soil and burns it off.

The graph shows approximate temperatures and times during a self-cleaning cycle for 3 hours.

SELF-CLEANING CYCLE – THREE HOUR SETTING
(Approximate Temperatures and Times)

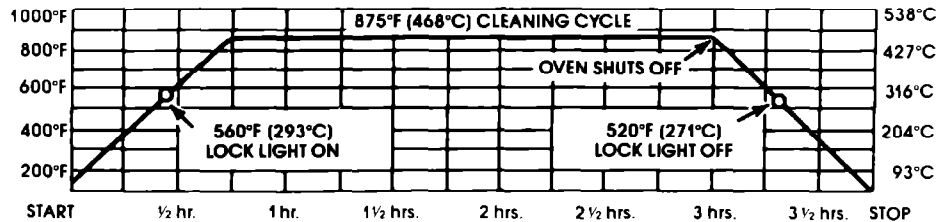

Notice that the heating stops when the 3-hour setting is up, but that it takes longer for the oven to cool down enough to unlock.

Cleaning Chart

PART	WHAT TO USE	HOW TO CLEAN
Exterior surfaces	Soft cloth and warm soapy water. Nylon or plastic scouring pad for stubborn spots.	<ul style="list-style-type: none"> Wipe off regularly when cooktop and lower oven are cool. Do not allow food containing acids (such as vinegar, tomato, lemon juice or milk) to remain on surface. Acids will remove the glossy finish. Do not use abrasive or harsh cleansers.
Surface units	No cleaning required.	<ul style="list-style-type: none"> Spatters or spills will burn off. Do not immerse in water.
Chrome reflector bowls	Automatic dishwasher or warm, soapy water and plastic scrubbing pad.	<ul style="list-style-type: none"> Wash with other cooking utensils. Clean frequently. Do not use abrasive or harsh cleansers.
Broiler pan and grid	Warm, soapy water or steel wool pad.	<ul style="list-style-type: none"> Wash with other cooking utensils.
Control knobs	Warm, soapy water and soft cloth.	<ul style="list-style-type: none"> Wash, rinse and dry well. Do not soak.
Control panel	Warm, soapy water or spray glass cleaner.	<ul style="list-style-type: none"> Wash, rinse and dry well. Follow directions provided with cleaner.
Oven racks	Self-Cleaning Oven cycle: warm, soapy water or soapy steel wool pads.	<ul style="list-style-type: none"> Leave in oven during Self-Cleaning cycle. Wash, rinse and dry. Use soapy steel wool pads for stubborn areas. <p>NOTE: The oven racks will discolor and be harder to slide when left in the self-cleaning cycle. If you want them to stay shiny, remove them from the oven and clean by hand.</p>
Self-Cleaning Oven	For areas outside Self-Cleaning area use warm, soapy water or soapy steel wool pads.	<ul style="list-style-type: none"> Follow directions starting on page 17, "Using the Self-Cleaning Cycle." Do not use commercial oven cleaners. Do not use foil to line the bottom of your Self-Cleaning Oven.

If you need service or assistance, we suggest you follow these five steps:

Performance problems often result from little things you can find and fix yourself without tools of any kind.

If nothing operates:

- Is the power supply cord plugged into a live circuit with the proper voltage? (See "Installation Instructions.")
- Have you checked your home's main fuses or circuit breaker box?

If the oven will not operate:

- Is the Oven Selector turned to a setting (BAKE or BROIL, but not TIMED BAKE)?
- Is the Oven Temperature Control turned to a temperature setting?

If surface units will not operate:

- Have you checked your home's main fuses or circuit breaker box?
- Are surface units plugged in all the way?
- Do the control knobs turn?

If surface unit control knob(s) will not turn:

- Did you push in before trying to turn?

If the Self-Cleaning cycle will not operate:

- Are the Oven Selector and Oven Temperature Control set on CLEAN?
- Does the Start Time Dial show the correct time of day?
- Is the Stop Time Dial set ahead to the time you want the cleaning cycle to stop?
- Is the Lock Lever all the way to the right? (The Clean Light will come on.)

If cooking results are not what you expected:

- Is the range level?
- Are you using pans recommended in the **Cooking Guide**?
- If baking, have you allowed 1½ to 2 inches (4-5 cm) on all sides of the pans for air circulation?
- Have you preheated the oven as the recipe calls for?
- Are the pans the size called for in the recipe?
- Are you following a tested recipe from a reliable source?
- Do the cooking utensils have smooth, flat bottoms and fit the surface unit being used?

See the **Cooking Guide** for more information on cooking problems and how to solve them.

2. If you need assistance*...

Call Whirlpool COOL-LINE® service assistance telephone number. Dial free from anywhere in the U.S.: 1-800-253-1301

and talk with one of our trained Consultants. The Consultants can instruct you in how to obtain satisfactory operation from your appliance or, if service is necessary, recommend a qualified service company in your area.

3. If you need service*...



Whirlpool has a nationwide network of franchised TECH-CARE® Service Companies. TECH-CARE service technicians are trained to fulfill the product warranty and provide after-warranty service, anywhere in the United States. To locate TECH-CARE service in your area, call our COOL-LINE service assistance telephone number (see Step 2) or look in your telephone directory Yellow Pages under:

APPLIANCES - HOUSEHOLD MAJOR - SERVICE & REPAIR	OR	ELECTRICAL APPLIANCES - MAJOR - REPAIRING & PARTS
WHIRLPOOL APPLIANCES FRANCHISED TECH-CARE SERVICE		WHIRLPOOL APPLIANCES FRANCHISED TECH-CARE SERVICE
<i>SERVICE COMPANIES</i> XYZ SERVICE CO 123 Maple 999-9999		<i>SERVICE COMPANIES</i> XYZ SERVICE CO 123 Maple 999-9999
OR		
WASHING MACHINES, DRYERS & IRONERS - SERVICING		
WHIRLPOOL APPLIANCES FRANCHISED TECH-CARE SERVICE		
<i>SERVICE COMPANIES</i> XYZ SERVICE CO 123 Maple 999-9999		

4. If you have a problem*...

Call our COOL-LINE service assistance telephone number (see Step 2) and talk with one of our Consultants, or if you prefer, write to:

Mr. Robert Stanley
Division Vice President
Whirlpool Corporation
2000 M-63
Benton Harbor, MI 49022

5. If you need FSP® replacement parts*...

FSP is a registered trademark of Whirlpool Corporation for quality parts. Look for this symbol of quality whenever you need a replacement part for your Whirlpool appliance. FSP replacement parts will fit right and work right, because they are made to the same exacting specifications used to build every new Whirlpool appliance.

To locate FSP replacement parts in your area, refer to Step 3 above or call the Whirlpool COOL-LINE service assistance number in Step 2.

*If you must call or write, please provide: model number, serial number, date of purchase, and a complete description of the problem. This information is needed in order to better respond to your request for assistance.

WHIRLPOOL MICROWAVE OVEN/ RANGE PRODUCT WARRANTY

LENGTH OF WARRANTY	WHIRLPOOL WILL PAY FOR
FULL ONE-YEAR WARRANTY From Date of Purchase	Replacement parts and repair labor to correct defects in materials or workmanship. Service must be provided by a franchised TECH-CARE® service company.
LIMITED FOUR-YEAR WARRANTY Second Through Fifth Year From Date of Purchase	Replacement magnetron tube on microwave ovens if defective in materials or workmanship.
WHIRLPOOL WILL NOT PAY FOR	
<p>A. Service calls to:</p> <ol style="list-style-type: none"> 1. Correct the installation of the range product. 2. Instruct you how to use the range product. 3. Replace house fuses or correct house wiring or plumbing. 4. Replace owner accessible light bulbs. <p>B. Repairs when range product is used in other than normal, single-family household use.</p> <p>C. Pick up and deliver. This product is designed to be repaired in the home.</p> <p>D. Damage to range product caused by accident, misuse, fire, flood, acts of God or use of products not approved by Whirlpool.</p> <p>E. Any labor costs during the limited warranty.</p>	

WHIRLPOOL CORPORATION SHALL NOT BE LIABLE FOR INCIDENTAL OR CONSEQUENTIAL DAMAGES. Some states do not allow the exclusion or limitation of incidental or consequential damages so this limitation or exclusion may not apply to you. This warranty gives you specific legal rights, and you may also have other rights which vary from state to state.

Outside the United States, a different warranty may apply. For details, please contact your franchised Whirlpool distributor or military exchange.



Part No. 3147417
©1987 Whirlpool Corporation

Printed in U.S.A.

Automatic Washers, Clothes Dryers, Freezers, Refrigerator-Freezers, Ice Makers, Dishwashers, Built-In Ovens and Surface Units, Ranges

